

**NorDan UK Ltd**3 Almondview Office Park
Livingston
EH54 6SF

Tel: 01506 433173

e-mail: info@nordan.co.uk

website: www.nordan.co.uk

**Agrément Certificate****07/4446**

Product Sheet 4

NORDAN TIMBER WINDOW RANGE**NORDAN ZD AND OD SINGLE-HANDLED TILT AND TURN INWARD OPENING WINDOWS**

This Agrément Certificate Product Sheet⁽¹⁾ relates to the NorDan ZD and OD Single-handed Tilt and Turn Inward Opening Windows, for use in new and existing dwellings, light commercial premises and similar applications.

(1) Hereinafter referred to as 'Certificate'.

CERTIFICATION INCLUDES:

- factors relating to compliance with Building Regulations where applicable
- factors relating to additional non-regulatory information where applicable
- independently verified technical specification
- assessment criteria and technical investigations
- design considerations
- installation guidance
- regular surveillance of production
- formal three-yearly review.

**KEY FACTORS ASSESSED**

Thermal properties — windows from within the range have a thermal transmittance value (U value) of $0.90 \text{ W}\cdot\text{m}^{-2}\cdot\text{K}^{-1}$ (see section 6).

Weathertightness — the system can be used in the exposure situations described in this Certificate (see section 7).

Ventilation — opening lights can provide rapid ventilation (see section 8).

Unauthorised access — windows from within the range can contribute to preventing unauthorised access to dwellings, light commercial premises and similar habitable applications (see section 9).

Durability — the windows will have a life of at least 25 years subject to the necessary maintenance being performed (see sections 15 and 16).



The BBA has awarded this Certificate to the company named above for the system described herein. This system has been assessed by the BBA as being fit for its intended use provided it is installed, used and maintained as set out in this Certificate.

On behalf of the British Board of Agrément

Date of First issue: 30 April 2020

Hardy Giesler
Chief Executive Officer

The BBA is a UKAS accredited certification body – Number 113.

The schedule of the current scope of accreditation for product certification is available in pdf format via the UKAS link on the BBA website at www.bbacerts.co.uk

Readers must check the validity and latest issue number of this Agrément Certificate by either referring to the BBA website or contacting the BBA directly.

Any photographs are for illustrative purposes only, do not constitute advice and should not be relied upon.

British Board of AgrémentBucknalls Lane
Watford
Herts WD25 9BA

©2020

tel: 01923 665300
clientservices@bbacerts.co.uk
www.bbacerts.co.uk



Regulations

In the opinion of the BBA, NorDan ZD and OD Single-handled Tilt and Turn Inward Opening Windows, if installed, used and maintained in accordance with this Certificate, can satisfy or contribute to satisfying the relevant requirements of the following Building Regulations (the presence of a UK map indicates that the subject is related to the Building Regulations in the region or regions of the UK depicted):



The Building Regulations 2010 (England and Wales) (as amended)

Requirement:	B1	Means of warning and escape
Comment:		Windows of an appropriate size can satisfy this Requirement. See section 11 of this Certificate.
Requirement:	C2(b)	Resistance to moisture
Comment:		The system has adequate resistance to the ingress of rain and wind-driven spray and so can contribute towards the wall satisfying this Requirement. See section 7.2 of this Certificate.
Requirement:	C2(c)	Resistance to moisture
Comment:		The system will not constitute a significant condensation risk so can contribute towards the wall satisfying this Regulation. See section 12.1 of this Certificate.
Requirement:	F1(1)	Means of ventilation
Comment:		The system can contribute to satisfying this Requirement. See section 8.1 of this Certificate.
Requirement:	K5.3	Safe opening and closing of windows etc (applicable to England only)
Comment:		The system can contribute to satisfying this Requirement. See section 13.2 of this Certificate.
Requirement:	K5.4	Safe access for cleaning windows etc (applicable to England only)
Comment:		This Requirement can be satisfied. See section 13.1 of this Certificate.
Requirement:	L1(a)(i)	Conservation of fuel and power
Comment:		The windows can contribute to satisfying this Requirement. See section 6.1 of this Certificate.
Requirement:	N3	Safe opening and closing of windows, etc (applicable to Wales only)
Comment:		The system can contribute to satisfying this Requirement. See section 13.2 of this Certificate.
Requirement:	N4	Safe access for cleaning windows etc (applicable to Wales only)
Comment:		This Requirement can be satisfied. See section 13.1 of this Certificate.
Requirement:	Q1	Unauthorised access
Comment:		The windows, as described in the Enhanced Security Sheet (ES4) for Product Sheet 4, can satisfy this Requirement for new dwellings. See section 9.3 of this Certificate.
Regulation:	7(1)	Materials and workmanship
Comment:		The system is acceptable. See sections 16.1 to 16.4 and the <i>Installation</i> part of this Certificate.
Regulation:	26	CO₂ emission rates for new buildings
Regulation:	26A	Fabric energy efficiency rates for new dwellings (applicable to England only)
Regulation:	26A	Primary energy consumption rates for new buildings (applicable to Wales only)
Regulation:	26B	Fabric performance values for new dwellings (applicable to Wales only)



Comment: The system can contribute to satisfying these Regulations See section 6.1 of this Certificate.



The Building (Scotland) Regulations 2004 (as amended)

Regulation:	8(1)(2)	Durability, workmanship and fitness of materials
Comment:		The system satisfies this Regulation. See sections 15 and 16.1 to 16.5 and the <i>Installation</i> part of this Certificate.
Regulation:	9	Building standards applicable to construction
Standard:	2.9	Escape
Comment:		The system can contribute to satisfying this Standard. See section 11 of this Certificate.
Standard:	3.10	Precipitation
Comment:		The system has adequate resistance to the ingress of rain and wind-driven spray and so can contribute towards the wall satisfying this Standard, with reference to clause 3.10.1 ⁽¹⁾⁽²⁾ . See section 7.2 of this Certificate.
Standard:	3.14	Ventilation
Comment:		The system can contribute to satisfying this Standard with reference to clauses 3.14.2 ⁽¹⁾⁽²⁾ and 3.14.3 ⁽¹⁾ of this Standard. See section 8.1 of this Certificate.
Standard:	3.15	Condensation
Comment:		The system will not constitute a significant condensation risk and so can contribute towards the wall satisfying this Standard, with reference to clauses 3.15.1 ⁽¹⁾ , 3.15.4 ⁽¹⁾ and 3.15.5 ⁽¹⁾⁽²⁾ . See section 12.1 of this Certificate.
Standard:	3.16	Natural lighting
Comment:		The system can contribute to satisfying this Standard with reference to clauses 3.16.1 ⁽¹⁾ and 3.16.3 ⁽¹⁾ of this Standard. See section 10 of this Certificate.
Standard:	4.8(c)	Danger from accidents
Comment:		Opening lights can satisfy this Standard with reference to clause 4.8.3 ⁽¹⁾⁽²⁾ . See section 13.1 of this Certificate.
Standard:	4.8(e)	Danger from accidents
Comment:		Opening lights can satisfy this Standard with reference to clause 4.8.5 ⁽¹⁾⁽²⁾ . See section 13.2 of this Certificate.
Standard:	4.13	Security
Comment:		The windows, as described in the Enhanced Security Sheet (ES4) for Product Sheet 4, can satisfy this Standard, with reference to clause 4.13.1(c) ⁽¹⁾ . See section 9.3 of this Certificate.
Standard:	6.1(b)	Carbon dioxide emissions
Standard:	6.2	Building insulation envelope
Comment:		The system can contribute to satisfying these Standards, with reference to clauses 6.1.1 ⁽¹⁾ , 6.1.2 ⁽¹⁾ , 6.1.4 ⁽²⁾ , 6.1.6 ⁽¹⁾ , 6.1.7 ⁽¹⁾ , 6.2.1 ⁽¹⁾⁽²⁾ , 6.2.4 ⁽²⁾ , 6.2.6 ⁽¹⁾ , 6.2.7 ⁽¹⁾ , 6.2.8 ⁽²⁾ , 6.2.9 ⁽¹⁾⁽²⁾ , 6.2.11 ⁽¹⁾⁽²⁾ and 6.2.13 ⁽¹⁾⁽²⁾ . See section 6.1 of this Certificate.
Standard:	7.1(a)(b)	Statement of sustainability
Comment:		The system can contribute to satisfying the relevant requirements of Regulation 9, Standards 1 to 6, and therefore will contribute to a construction meeting a bronze level of sustainability as defined in this Standard. In addition, the system can contribute to a construction meeting a higher level of sustainability as defined in this Standard, with reference to clauses 7.1.4 ⁽¹⁾⁽²⁾ [Aspects 1 ⁽¹⁾⁽²⁾ and 2 ⁽¹⁾], 7.1.6 ⁽¹⁾⁽²⁾ [Aspects 1 ⁽¹⁾⁽²⁾ and 2 ⁽¹⁾] and 7.1.7 ⁽¹⁾⁽²⁾ [Aspect 1 ⁽¹⁾⁽²⁾]. See section 6.1 of this Certificate.



Regulation: 12 **Building standards applicable to conversions**
 Comment: All comments given for this system under Regulation 9, Standards 1 to 6, also apply to this Regulation, with reference to clause 0.12.1⁽¹⁾⁽²⁾ and Schedule 6⁽¹⁾⁽²⁾.

(1) Technical Handbook (Domestic).
 (2) Technical Handbook (Non-Domestic).



The Building Regulations (Northern Ireland) 2012 (as amended)

Regulation: 23	Fitness of materials and workmanship
Comment:	The system is acceptable. See sections 16.1 to 16.4 and the <i>Installation</i> part of this Certificate.
Regulation: 28(b)	Resistance to moisture and weather
Comment:	The system has adequate resistance to the ingress of rain and wind-driven spray and so can contribute towards the wall satisfying this Regulation. See section 7.2 of this Certificate.
Regulation: 29	Condensation
Comment:	The system will not constitute a significant condensation risk and so can contribute towards the wall satisfying this Regulation. See section 12.1 of this Certificate.
Regulation: 33(c)	Means of escape
Comment:	The system can contribute to satisfying the Regulation. See section 11 of this Certificate.
Regulation: 39(a)(i)	Conservation measures
Regulation: 40(2)	Target carbon dioxide emission rate
Comment:	The system can contribute to satisfying these Regulations. See section 6.1 of this Certificate.
Regulation: 65(1)	Means of ventilation
Comment:	The system can contribute to satisfying this Regulation. See section 8.1 of this Certificate.
Regulation: 98	Safe opening and closing of windows, skylights and ventilators
Comment:	The requirements of this Regulation are considered to be satisfied if the window complies with Technical Booklet V, Section 4. See section 13.2 of this Certificate.
Regulation: 99	Safe means of access for cleaning glazing
Comment:	Opening lights can satisfy this Regulation. See section 13.1 of this Certificate.

Construction (Design and Management) Regulations 2015

Construction (Design and Management) Regulations (Northern Ireland) 2016

Information in this Certificate may assist the client, designer (including Principal Designer) and contractor (including Principal Contractor) to address their obligations under these Regulations.

See sections: 3 *Delivery and site handling* (3.3) and 13 *Safety* (13.7) of this Certificate.

Additional Information

NHBC Standards 2020

In the opinion of the BBA, NorDan ZD and OD Single-handed Tilt and Turn Inward Opening Windows, if installed, used and maintained in accordance with this Certificate, can satisfy or contribute to satisfying the relevant requirements in relation to *NHBC Standards*, Chapter 6.7 *Doors, windows and glazing*.



CE marking

The Certificate holder has taken the responsibility of CE marking the products in accordance with harmonised Standard BS EN 14351-1 : 2006.

Technical Specification

1 Description

1.1 NorDan ZD and OD Single-handled Tilt and Turn Inward Opening Windows (see Figure 1) are manufactured from preserved North European Redwood, factory-finished painted or externally clad in aluminium, with a polyester powder coating in any standard RAL colour. Windows can be supplied uncoated on request, subject to the Certificate holder's approval, but the durability of these windows has not been assessed.

Figure 1 Corner detail



1.2 The windows comprise single tilt and turn inward opening windows (Juliet balcony door-sized windows), subject to the limitations shown in Table 1 and glazed with sealed, triple-glazed units⁽¹⁾. The range is also available with multilight combinations, comprising fixed and opening lights.

(1) Outside the scope of this Certificate.

Table 1 Limitations

Feature	Window style	Value
Maximum size	Opening tilt and turn lights	2290 mm high x 1890 mm wide
Maximum opening sash weight		120 kg

1.3 Framing members comprise profiled North European Redwood sections, formed by cutting the required profiles from engineered timber. After profiling and machining, the timber is preservative-treated using a vacuum-impregnation technique to EN 351-1 : 2007.



Figure 2 Typical vertical section

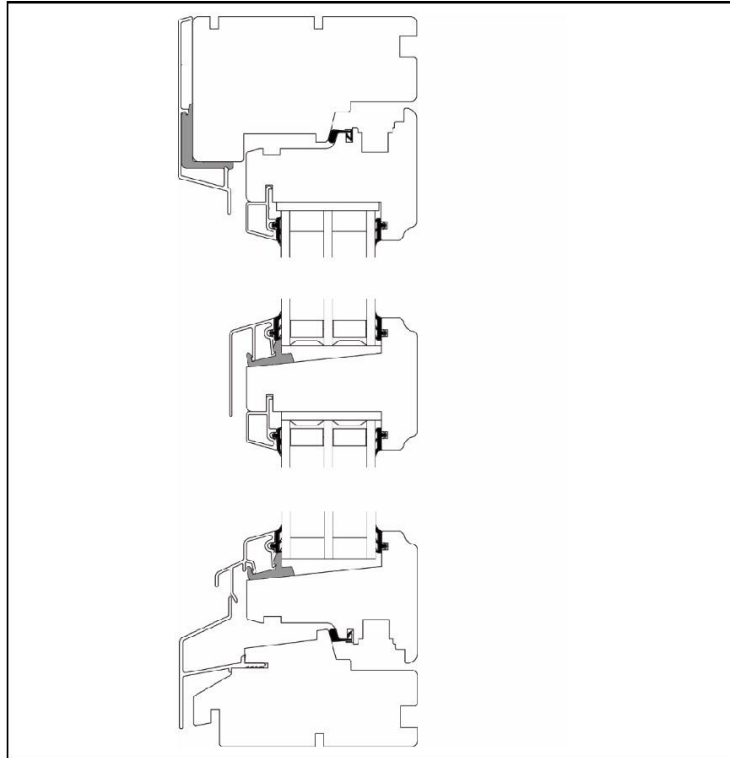
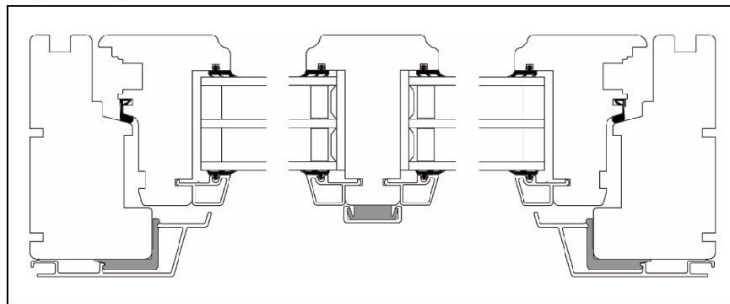

Figure 3 Typical horizontal section



Fittings

1.4 The windows are fitted with specific types of tilt and turn mechanisms, approved for the purpose by the BBA, and an espagnolette-type locking system. Hinges are formed from yellow chromatised zinc alloy, with the tilt stay formed from steel.

1.5 The tilt and turn mechanism locates in a purpose-made groove in the opening light profile. All furniture is screwed to the timber-frame profiles using corrosion-resistant screws.

1.6 The multi-point locking espagnolette engages with keeps fixed to the outer frame, and is operated by a handle manufactured from zinc alloy coated in various colours.

Glazing

1.7 Windows are supplied factory glazed using triple-glazed units⁽¹⁾, with glass thicknesses in accordance with BS 6262-1 : 2017. The triple-glazed units comprise a 4 mm thick outer pane, an argon-filled cavity of 16 mm, a 4 mm thick centre pane, an argon-filled cavity of 16 mm and a 4 mm inner pane. Other types of glass units are available from the Certificate holder but these have not been assessed. Windows as described in the Enhanced Security Sheet (ES4) for



Product Sheet 4, feature a 6/16/4/16/4 mm toughened or laminated glass, sealed unit. All glass is positioned by plastic setting blocks and packing pieces.

⁽¹⁾ Outside the scope of this Certificate

1.8 The glazing units must satisfy the requirements of BS EN 1279-2 : 2018 and (if relevant) BS EN 1279-3 : 2018.

1.9 NHBC require⁽¹⁾ that compliance to the standards referred to in sections 1.7 and 1.8 is confirmed by an appropriate independent technical approvals authority.

⁽¹⁾ NHBC Standards 2020, Chapter 6.7.7, *Glazing, insulating glass units.*

Weatherstripping and gaskets

1.10 Glazing units are sealed into the wooden sash using a polyurethane adhesive sealant.

1.11 Glazing beads are manufactured from aluminium and are polyester powder coated in any standard RAL colour.

1.12 Q-LON weatherstripping is located in grooves around the periphery of the opening light.

2 Manufacture

2.1 NorDan ZD and OD Single-handled Tilt and Turn Inward Opening Windows are manufactured from preserved North European Redwood, formed by cutting the required profiles from engineered timber and factory-finished painted or externally clad in aluminium with a polyester powder coating in any standard RAL colour.

2.2 As part of the assessment and ongoing surveillance of product quality, the BBA has:

- agreed with the manufacturer the quality control procedures and product testing to be undertaken
- assessed and agreed the quality control operated over batches of incoming materials
- monitored the production process and verified that it is in accordance with the documented process
- evaluated the process for management of nonconformities
- checked that equipment has been properly tested and calibrated
- undertaken to carry out the above measures on a regular basis through a surveillance process, to verify that the specifications and quality control operated by the manufacturer are being maintained.

2.3 The management system of the manufacturer has been assessed and registered as meeting the requirements of BS EN ISO 9001 : 2015 by Nemko Certification AS (Certificate 800003).

3 Delivery and site handling

3.1 The windows are generally delivered to site ready glazed. For transportation, they are set securely on timber pallets which are then factory shrink-wrapped and steel-banded to provide protection against surface damage. Care must be taken during all subsequent site handling processes to avoid the risk of damage. Each window is marked with the customer's reference production serial number, and glass size and make-up for easy identification on site.

3.2 The windows should be stored in accordance with the Certificate holder's recommendations.

3.3 The weight of the glazed frame (which can be obtained from the Certificate holder) and its ease of handling, particularly by one person, must be taken into account when planning site operations.

Assessment and Technical Investigations

The following is a summary of the assessment and technical investigations carried out on NorDan ZD and OD Single-handled Tilt and Turn Inward Opening Windows.



Design Considerations

4 Use

NorDan ZD and OD Single-handled Tilt and Turn Inward Opening Windows are satisfactory for use in non-loadbearing applications where windows are installed vertically into the external walls of new and existing dwellings, light commercial premises and similar applications.

5 Practicability of installation

The system is designed to be installed by a competent general builder, or a contractor, experienced with this type of system.

6 Thermal properties



6.1 When calculated according to BS EN ISO 10077-1 : 2017 and BS EN ISO 10077-2 : 2017, the thermal transmittance value (U value) of a NorDan ZD and OD Single-handled Tilt and Turn window, 1230 mm wide by 1480 mm high, incorporating a tilt and turn light and a fixed light, and glazed as described in section 1.7 with a sealed triple-glazed, argon-filled unit, is $0.90 \text{ W}\cdot\text{m}^{-2}\cdot\text{K}^{-1}$.

6.2 The overall thermal insulation of the window will be dependent on the performance of the triple-glazed units. For units other than that described in section 6.1, the indicative U values shown in Table 6e of SAP 2012 *The Government's Standard Assessment Procedure for Energy Rating of Dwellings* can be used. When available, a certified U value by measurement to BS EN ISO 12567-1 : 2010 or calculation to BS EN ISO 10077-1 : 2017 and BS EN ISO 10077-2 : 2017 should be used in preference.

6.3 Design U values are detailed in the documents supporting the national Building Regulations.

7 Weathertightness

7.1 Selected samples from the NorDan ZD and OD Single-handled Tilt and Turn Inward Opening windows were tested for weathertightness in accordance with EN 14351-1 : 2006, EN 1026 : 2016, EN 1027 : 2016 and EN 12211 : 2016, and are suitable for use as indicated in Table 2 of this Certificate. The classifications are based on the assumption that the outer frame is supported on all four sides in accordance with the Certificate holder's instructions. These test results are indicative and only valid for the windows tested. If classification for a particular window is required, and it is not covered within Table 2, the window should be tested in accordance with BS EN 14351-1 : 2006.



7.2 The classifications in Table 2 can be used to determine suitability when selecting exposure category, in conjunction with Annex A of BS 6375-1 : 2015.

Table 2 Weathertightness classifications

Window style	Classification according to:			
	Resistance to wind load classified to BS EN 12210 : 2016	Watertightness classified to BS EN 12208 : 2000	Air permeability classified to BS EN 12207 : 2016	UK exposure category rating to BS 6375-1 : 2015
ZD and OD Single-handled Tilt and Turn Windows, 1484 mm wide x 2488 mm high	Class C3	Class E1200	Class 4	1200

7.3 For unusual building layouts, building shapes or ground topography, the designer will need to give particular consideration to the prevailing exposure conditions.



8 Ventilation



8.1 The opening area for natural ventilation may be calculated by multiplying together the overall width and height dimensions of the frame containing the opening lights, reduced by the relevant profile dimension.

8.2 The background ventilation requirements of the various national Building Regulations can be satisfied by the incorporation in the window of a suitably sized trickle ventilator⁽¹⁾.

(1) Outside the scope of this Certificate.

9 Unauthorised access

9.1 Opening lights (fitted with lock mechanisms as described in sections 1.4 and 1.6 of this Certificate) when fastened in the closed position, cannot be opened by manipulation from the outside (for example, by the insertion of a thin blade) and can contribute to offering security against intrusion.

9.2 Key-operated handles are required for certain windows to satisfy the security requirements of *NHBC Standards 2020 Chapter 6.7 Doors, windows and glazing*.



9.3 Windows, as described in the Enhanced Security Sheet (ES4) for Product Sheet 4, have been tested in accordance with PAS 24 : 2016, Annex C and can contribute to satisfying the regulatory requirements for unauthorised access in new dwellings for England and Wales and new and existing dwellings in Scotland.

9.4 Attention should be paid to packing of glazing units adjacent to all locking points. In addition, frame fixings should coincide with the locating points of the locking system, with suitable packing installed between the frame and the fabric of the building.

9.5 Externally fitted glazing beads can be removed but subsequent removal of the glass without breakage and noise is extremely difficult due to the glazing being additionally secured with polyurethane sealant.

10 Glass area



The approximate unobstructed glass area of the windows is determined by deducting from the overall width and height, the appropriate profile dimensions. Typical dimensions are given in Table 3.

Table 3 Typical dimensions for determining unobstructed glass area

Window feature	Dimension (mm)
Outer frame and opening light	
— jamb	94
— head	105
Outer frame (sill) and opening light	101

11 Unobstructed opening area



11.1 A window can provide an adequate means of escape from a dwelling when it incorporates an opening light that:

- is in a room with a floor not more than 4.5 m above ground level
- is positioned so that the bottom of the opening is no more than 1.1 m above the floor



- provides a clear opening area of at least 0.33 m² and not less than 450 mm high by 450 mm wide, which may be at an angle or straight through. The obstruction caused by opening lights hung on projecting friction stays must be taken into account when the clear opening is determined.

11.2 In addition:

England and Wales — windows must remain open without needing to be held

Scotland — locks may be used but must not cause a permanent obstruction to satisfy clause 2.9.4⁽¹⁾ as escape windows

⁽¹⁾ Technical Handbook (Domestic).

Northern Ireland — the window must be positioned at least 800 mm above the floor.

12 Condensation risk



12.1 In normal domestic or similar applications, timber windows will not constitute a significant condensation risk when correctly installed.

12.2 Guidance on satisfactory design details is given in *Limiting thermal bridging and air leakage : Robust construction details for dwellings and similar buildings*, TSO 2002 and the *Accredited Construction Details*. Further information is contained in BRE Report BR 262 : 2002.

13 Safety



13.1 Windows from the system open in, and can be safely cleaned from inside the building.

13.2 The windows can comply with the recommendations of BS 8213-1 : 2004 with regard to the positioning of hand-operated controls.

13.3 Reasonable provision must be made to minimise the risk of people colliding with an open window when moving in or about a building, in accordance with the documents supporting the national Building Regulations.

13.4 Transparent glazing, of which people may be unaware and with which they are likely to collide, must incorporate features which make it apparent. The documents supporting the national Building Regulations include ways of complying with this requirement.

13.5 Approved Document K4 to the Building Regulations (England), Approved Document N1 to the Building Regulations (Wales), *NHBC Standards*, 2020, Appendix 6.7.7, and BS 6262-4 : 2018⁽¹⁾, make recommendations to ensure the safe performance of glazing. These include the use of safety glass complying with BS EN 12600 : 2002 in locations where accidental collision is likely. The windows can be supplied with toughened or laminated glazing units, but the performance of the glazing units is outside the scope of this Certificate.

⁽¹⁾ Dealing with the safety of people upon impact with the glazing.

13.6 When selecting the means of access during the period of installation (for example, use of scaffolding), the safety of operatives, occupants and passers-by should be considered.

14 Ease of operation

The windows can be operated without difficulty when correctly installed.



15 Maintenance



15.1 The windows can be re-glazed and the gaskets and weatherstripping replaced. If the gasket is damaged on a glazing bead (for example, during re-glazing), the gasket may be replaced. These operations should be carried out by a suitably qualified and experienced individual using the materials recommended by the Certificate holder and approved by the BBA.

15.2 If damage occurs, the furniture and fittings can be replaced.

15.3 The tilt and turn gear, hinges and locking mechanism should be cleaned and lubricated periodically in accordance with the manufacturer's instructions, to minimise wear and to ensure smooth operation. More frequent lubrication may be required depending on the environmental conditions.

15.4 The seal to the building structure will need to be replaced within the life of the window.

15.5 The painted coating/polyester powder coating can be cleaned using a soft sponge and soapy water. Solvent-based, corrosive or abrasive cleaners must not be used. If dirt is allowed to build up on the coating over long periods it may become more difficult to restore the surface appearance.

15.6 Care should be taken when using proprietary materials for cleaning the glass, to ensure that deposits are not allowed to remain on the frames where they may cause discoloration and damage to the surface. In addition, care must be taken to avoid damage to, or discoloration of, the members when stripping paint from adjacent timber (for example, by means of a blowlamp or paint stripper).

15.7 If damage occurs to the painted coating, repairs should be carried out as described in the Certificate holder's instructions using paints⁽¹⁾ recommended by the Certificate holder.

{1} Outside the scope of this Certificate.

16 Durability



16.1 The windows will have a service life of at least 25 years, subject to the necessary maintenance being carried out as described in section 15 of this Certificate. This may be extended to up to 60 years for the coloured coating system, provided that it is regularly overcoated in accordance with section 16.3 of this Certificate.

16.2 The timber members of the frame are preservative pre-treated with an effective fungicide to EN 351-1 : 2007.

16.3 The coloured coating system used on the wooden surfaces has good chemical resistance and colour stability and will retain its appearance for at least 10 years without redecoration. The coating adheres well to the substrate and will retain its integrity for a similar period. The coating, however, may need to be repainted within this period using paints⁽¹⁾ recommended by the Certificate holder.

{1} Outside the scope of this Certificate.

16.4 Fittings, including the tilt and turn gear, hinges, locking mechanism and operating handles, as described in this Certificate, will have a durability of 25 years, except where windows are to be installed in areas subject to particularly aggressive conditions. These conditions can prevail in coastal locations or near sources of industrial pollutants and replacement of fittings may be necessary within the life of the window.



16.5 The gaskets, weatherstripping and fittings may need to be replaced within the life of the window.

16.6 Any slight colour change or surface dulling of the painted coating which might occur will be uniform over the visible surfaces of the windows.



17 Reuse and recyclability

The timber frame members and aluminium cladding sections of the system can be recycled.

Installation

18 General

18.1 The window must be fixed into the opening, in accordance with the Certificate holder's installation instructions and BS 8213-4 : 2016, using appropriate fixing screws and/or proprietary expanding anchors through the frame or galvanized steel fixing lugs.

18.2 Openings in new walls should be formed, making suitable allowance for fitting tolerances. As details may vary depending on the type of construction being employed, tolerances should be discussed with the Certificate holder prior to establishing the manufacturing dimensions for the window.

18.3 In common with other types of window fitted to prepared openings, the system must be correctly positioned in relation to damp-proof courses to prevent water penetration to the internal reveal.

18.4 The provision of a cavity closer and/or cavity barrier around the window opening, prior to the installation, may be required. Details of products covered by an Agrément Certificate can be found on the BBA website (www.bbacerts.co.uk).

Technical Investigations

19 Tests

19.1 Tests were carried out and the results assessed to determine:

- air permeability
- watertightness
- effect of wind loads
- operation and strength
- efficiency and corrosion resistance of window furniture
- basic security
- enhanced security.

19.2 Tests were carried out, generally in accordance with BS 644 : 2012.

19.3 Durability tests were carried out to assess the life of the coating on the timber profiles and aluminium bead and cladding sections regarding:

- colour stability
- coating thickness
- water absorption
- cross-cut adhesion.

20 Investigations

20.1 The thermal transmittance value of a NorDan ZD and OD Single-handled Tilt and Turn Inward Opening Window was calculated in accordance with BS EN ISO 10077-1 : 2017 and BS EN ISO 10077-2 : 2017.

20.2 The manufacturing process was evaluated, including the methods adopted for quality control, and details were obtained of the quality and composition of the materials used.



Bibliography

- BRE Report BR 262 : 2002 *Thermal Insulation : avoiding risks*
- BS 644 : 2012 *Timber windows and doorsets — Fully finished factory-assembled windows and doorsets of various types — Specification*
- BS 6262-1 : 2017 *Glazing for buildings — General methodology for the selection of glazing*
BS 6262-4 : 2018 *Glazing for buildings — Code of practice for safety related to human impact*
- BS 6375-1 : 2015 + A1 : 2016 *Performance of windows — Classification for weathertightness and guidance on selection and specification*
- BS 8213-1 : 2004 *Windows, doors and rooflights — Design for safety in use and during cleaning of windows, including door-height windows and roof windows — Code of practice*
BS 8213-4 : 2016 *Windows and doors — Code of practice for the survey and installation of windows and external doorsets*
- BS EN 1279-2 : 2018 *Glass in building — Insulating glass units — Long term test method and requirements for moisture penetration*
BS EN 1279-3 : 2018 *Glass in building — Insulating glass units — Long term test method and requirements for gas leakage rate and for gas concentration tolerances*
- BS EN 12207 : 2016 *Windows and doors — Air permeability — Classification*
BS EN 12208 : 2000 *Windows and doors — Watertightness — Classification*
BS EN 12210 : 2016 *Windows and doors — Resistance to wind load — Classification*
BS EN 12600 : 2002 *Glass in building — Pendulum test — Impact test method and classification for flat glass*
BS EN 14351-1 : 2006 + A2 : 2016 *Windows and doors — Product standard, performance characteristics — Windows and external pedestrian doorsets*
BS EN ISO 9001 : 2015 *Quality management systems — Requirements*
BS EN ISO 10077-1 : 2017 *Thermal performance of windows, doors and shutters — Calculation of thermal transmittance — General*
BS EN ISO 10077-2 : 2017 *Thermal performance of windows, doors and shutters — Calculation of thermal transmittance — Numerical method for frames*
BS EN ISO 12567-1 : 2010 *Thermal performance of windows and doors — Determination of thermal transmittance by hot box method — Complete windows and doors*
EN 351-1 : 2007 *Durability of wood or wood-based products — Preservative-treated solid wood — Classification of preservative penetration and retention*
EN 1026 : 2016 *Windows and doors — Air permeability — Test method*
EN 1027 : 2016 *Windows and doors — Watertightness — Test method*
EN 12211 : 2016 *Windows and doors — Resistance to wind load — Test method*
PAS 24 : 2016 *Enhanced security performance requirements for doorsets and windows in the UK — Doorsets and windows intended to offer a level of security suitable for dwellings and other buildings exposed to comparable risk*



Conditions of Certification

21 Conditions

21.1 This Certificate:

- relates only to the product/system that is named and described on the front page
- is issued only to the company, firm, organisation or person named on the front page – no other company, firm, organisation or person may hold or claim that this Certificate has been issued to them
- is valid only within the UK
- has to be read, considered and used as a whole document – it may be misleading and will be incomplete to be selective
- is copyright of the BBA
- is subject to English Law.

21.2 Publications, documents, specifications, legislation, regulations, standards and the like referenced in this Certificate are those that were current and/or deemed relevant by the BBA at the date of issue or reissue of this Certificate.

21.3 This Certificate will remain valid for an unlimited period provided that the product/system and its manufacture and/or fabrication, including all related and relevant parts and processes thereof:

- are maintained at or above the levels which have been assessed and found to be satisfactory by the BBA
- continue to be checked as and when deemed appropriate by the BBA under arrangements that it will determine
- are reviewed by the BBA as and when it considers appropriate.

21.4 The BBA has used due skill, care and diligence in preparing this Certificate, but no warranty is provided.

21.5 In issuing this Certificate the BBA is not responsible and is excluded from any liability to any company, firm, organisation or person, for any matters arising directly or indirectly from:

- the presence or absence of any patent, intellectual property or similar rights subsisting in the product/system or any other product/system
- the right of the Certificate holder to manufacture, supply, install, maintain or market the product/system
- actual installations of the product/system, including their nature, design, methods, performance, workmanship and maintenance
- any works and constructions in which the product/system is installed, including their nature, design, methods, performance, workmanship and maintenance
- any loss or damage, including personal injury, howsoever caused by the product/system, including its manufacture, supply, installation, use, maintenance and removal
- any claims by the manufacturer relating to CE marking.

21.6 Any information relating to the manufacture, supply, installation, use, maintenance and removal of this product/system which is contained or referred to in this Certificate is the minimum required to be met when the product/system is manufactured, supplied, installed, used, maintained and removed. It does not purport in any way to restate the requirements of the Health and Safety at Work etc. Act 1974, or of any other statutory, common law or other duty which may exist at the date of issue or reissue of this Certificate; nor is conformity with such information to be taken as satisfying the requirements of the 1974 Act or of any statutory, common law or other duty of care.